



6LY2A-UTP / STP Series

	6LY2A-UTP	6LY2A-STP
Configuration	4-stroke, vertical, water-cooled diesel engine	
Maximum output at crankshaft		* 324 kW (440mhp) @3300 rpm
	** 272 kW (370mhp) @3300 rpm	** 315 kW (427mhp) @3300 rpm
Displacement	5.813 ltr	[354 cu in]
Bore x stroke	106 mm x 110 mm	[4.17 in x 4.33 in]
Cylinders	6 in line	
Combustion system	Direct injection	
Aspiration	Turbocharged with watercooled turbine housing	
Starting system	Electric starting 12V - 3 kW	
Alternator	12V - 80A	
Cooling system	Fresh water cooling by centrifugal fresh water pump and rubber impeller seawater pump	
Lubrication system	Enclosed, forced lubricating system	
Direction of rotation [crankshaft]	Counter clockwise viewed from stern	
Dry weight without gear	535 kg	[1179 lbs]
Environmental	EU: RCD	IMO Tier2
Engine mounting	Rubber type flexible mounting	

NOTE:

1 kW = 1.3596 mhp

* Fuel temperature 25°C Fuel gravity 860g/litter [ISO 3046-1], fuel density at 15°C: 860g/litter

** Fuel temperature 40°C Fuel gravity 840g/litter [ISO 8665: 2006], fuel density at 15°C: 840g/litter

Technical data is according to ISO 8665: 2006/3046-1

DIMENSIONS

Rear view

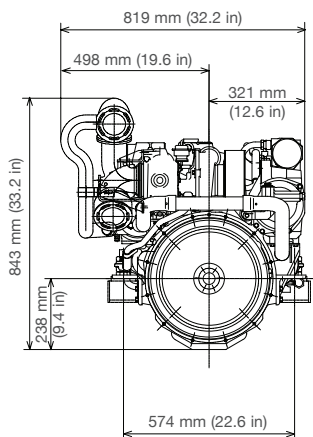

Right side view

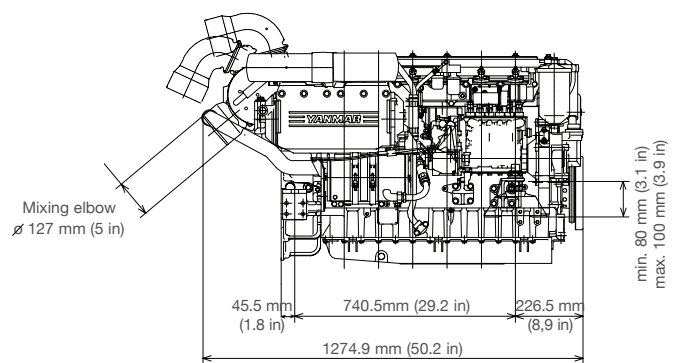

6LY2A-UTP / STP (Bobtail)



PERFORMANCE CURVES

6LY2A-UTP

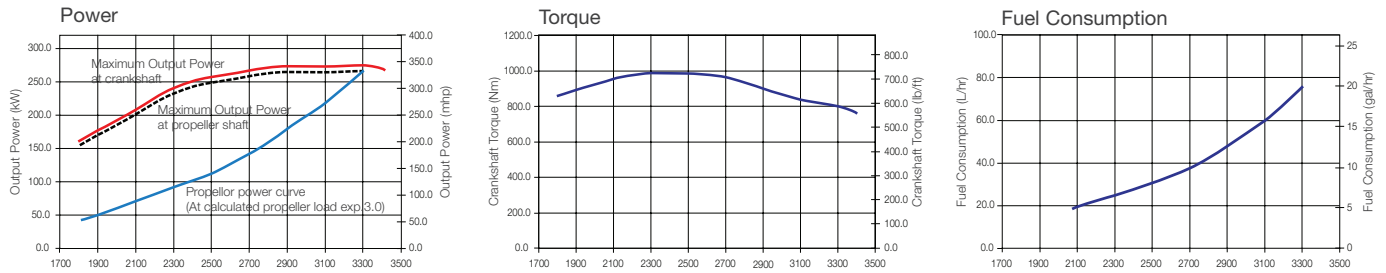

6LY2A-STP

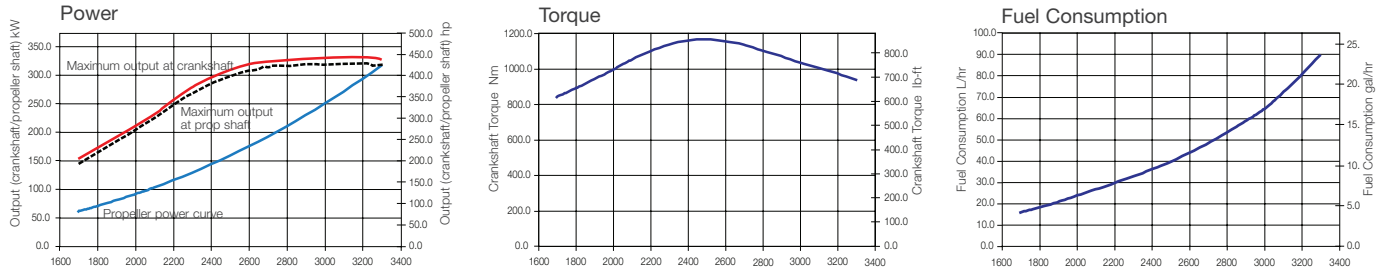

MARINE GEARS / DRIVE

Model	KMH60A		
Type	Hydraulically actuated multi-disc clutch		
Dry weight	58 kg [128 lbs]		
Reduction ratio [fwd/asn]	1.55/1.55	2.04/2.04	2.43/2.43
Propeller speed [fwd/asn]	2000/2000	1520/1520	1276/1276
Direction of rotation [propeller shaft - fwd]	Clockwise & Counterclockwise viewed from stern		
Dry weight engine and gear/drive	593 kg [1305 lbs]		
Length engine and gear/drive	1310 mm [51 in]		

* Other marine gearboxes and configurations available upon request. Contact your local supplier for more information. Following gears are available: ZF80A (down angle) reduction ratio: 1.567, 1.750, 1.962, 2.500
 MG5050A (down angle) reduction ratio: 1.12, 1.26, 1.50, 1.80, 2.04, 2.50

INSTRUMENT PANELS

New B-type Panel

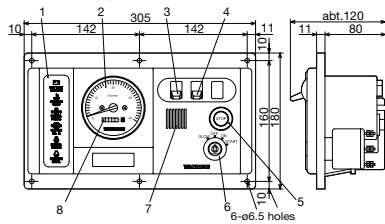

New C-type Panel

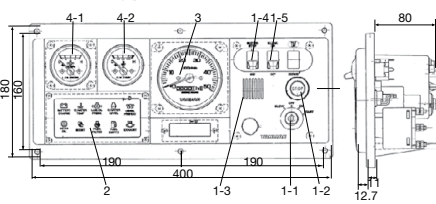

New D-type Panel

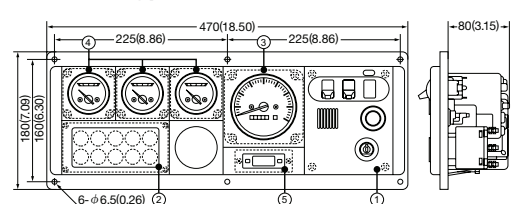

Function

1-Switch unit

- 1-1 Key switch [starter switch]
- 1-2 Engine stop switch
- 1-3 Alarm buzzer [C.W. Temp., L.O. Pressure]
- 1-4 Alarm buzzer stop switch
- 1-5 Illumination switch for meters

2-Alarm lamp unit

- 2-1 Battery not charging
- 2-2 C.W. high temperature
- 2-3 L.O. low pressure
- 2-4 Sea water flow
- 2-5 C.W. level for fresh water tank
- 2-6 Boost pressure high

3-Tachometer with hour meter

- 4-Sub meter unit**
- 4-1 L.O. pressure meter
- 4-2 C.W. Temperature meter
- 4-3 Boost meter [turbo]
- 5-Quartz clock**

ACCESSORIES

Standard engine package

- Sensor for various panels
- Exhaust/water mixing elbow [L-type]
- Alternator 12V - 80A

Optional accessories

- Flexible mounts
- Fuel water separator
- High-riser/water mixing elbow [instead of L-elbow]
- Sensor for VDO instrument panels
- Analog [new B-type, new C-type and new D-type] instrument panels
- Control heads
- Lub oil evacuation pump
- Dipstick for opposite side
- SOLAS Kit

NOTE: All data subject to change without notice. Text and illustrations are not binding.

www.yanmar.eu