



4LV Series - 150 / 170 / 195

Configuration	In-line, 4-stroke, vertical, water-cooled diesel engine	
Max. output at crankshaft*	110 kW@3500 rpm	[150 mhp@3500 rpm]
	125 kW@3500 rpm	[170 mhp@3500 rpm]
	143 kW@3500 rpm	[195 mhp@3500 rpm]
No. of cylinders	4 cylinder	
Displacement	2.755 L	[168 cu in]
Bore x stroke	92 mm x 103.6 mm	[3.6 in x 4 in]
Aspiration	Turbocharged & intercooled	
Combustion system	Direct injection, Denso common rail system	
Starting system	Electric starting 12V – 2 kW	
Engine management	Electronic	
Cooling system	Fresh water cooling by centrifugal fresh water pump	
	Seawater cooling by rubber impeller seawater pump	
Alternator	Denso 12V - 130A	
Lubrication system	Enclosed, forced lubricating system	
Engine lube oil specifications	API class: CD or higher, SAE grade: 15W-40	
Direction of rotation at crankshaft	Counterclockwise (CCW) viewed from stern	
Dry weight without gear	334 kg	[736 lbs]
Engine dimensions† L x W x H	1151 x 755 x 772 mm	
Emission compliance	EU: RCD 2, BSO II, IMO,^ EMC	US: EPA Tier 3, EPA-C
Flywheel housing size	Borg Warner / SAE #7	
Controls	Mechanical (optional - VC20 system)	

NOTE: Fuel condition: Density at 15°C = 0.84 g/cm³; 1 kW = 1.3596 mhp = 1.3410 HP

Technical data is according to ISO 8665: 2006

* Fuel temperature 40°C at the inlet of the fuel injection pump [ISO 8665: 2006]

†Length includes KMH50A marine gear (Dimensions may vary with other gears/elbow)

^4LV195 only

DIMENSIONS

Rear view

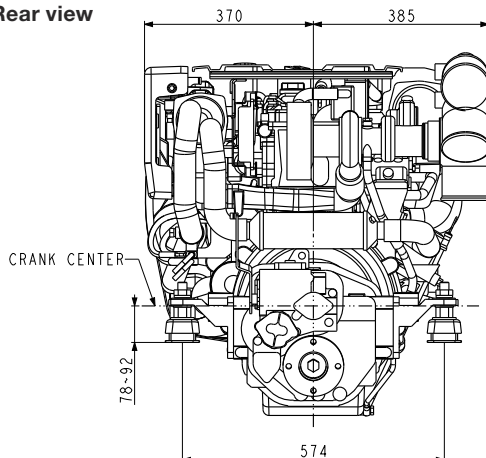

Right side view

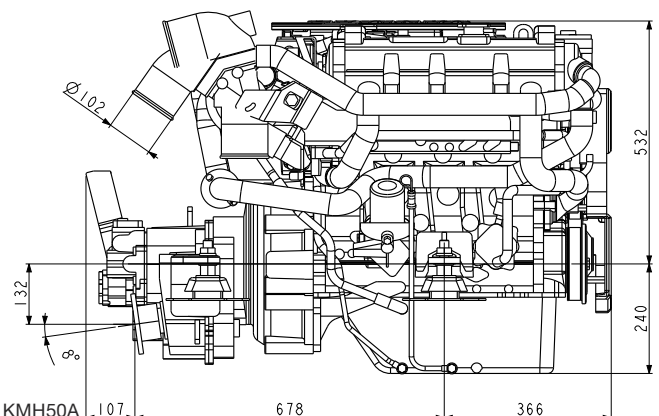

(Not to be used for engine installation)



PERFORMANCE CURVES

4LV150 Torque curve

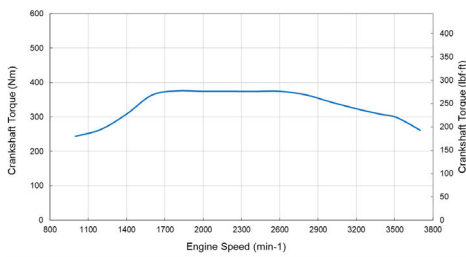

4LV150 Output Power curve

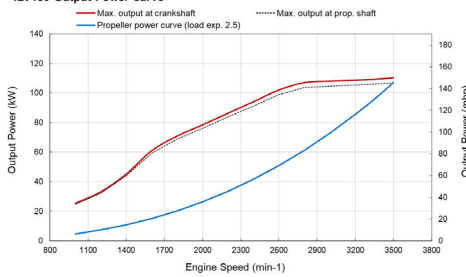

4LV150 Fuel consumption (load exp. 2.5)

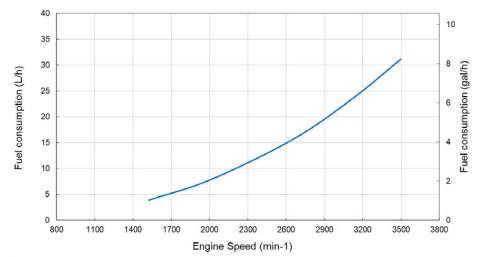

4LV170 Torque curve

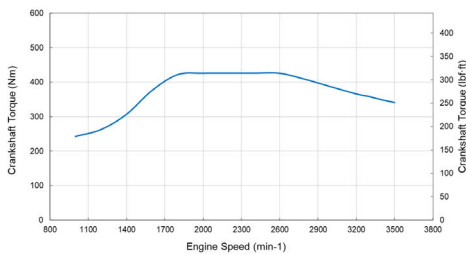

4LV170 Output Power curve

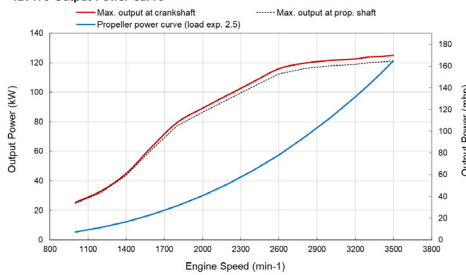

4LV170 Fuel consumption (load exp. 2.5)

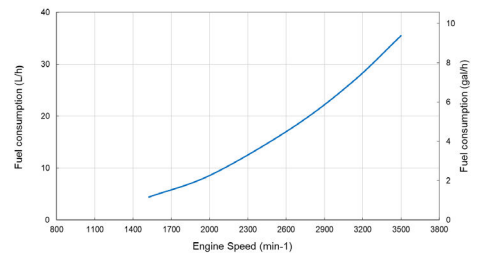

4LV195 Torque curve

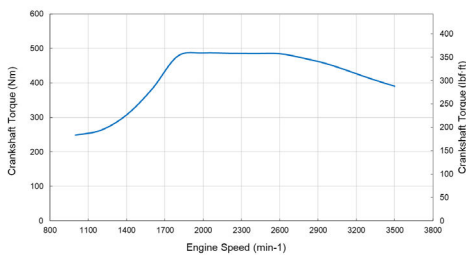

4LV195 Output Power curve

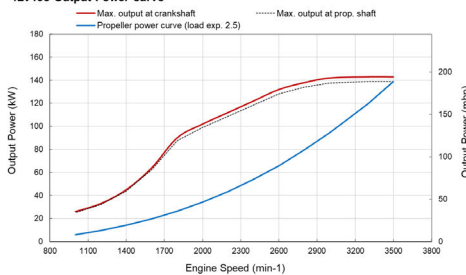

4LV195 Fuel consumption (load exp. 2.5)

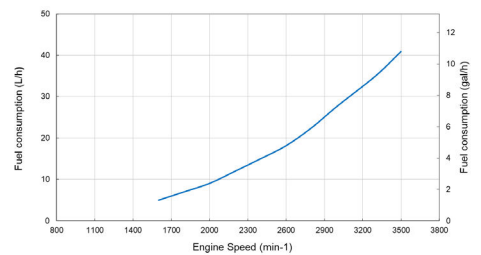

MARINE GEAR*

Model	KMH50A [down angle: 8°]			KMH50V [V-drive, angle: 12°]		
Clutch type	Hydraulic multi-disc			Hydraulic multi-disc		
Dry weight	54 kg [119 lbs]			77 kg [165 lbs]		
Reduction ratio [fwd/asn]	1.67/1.67	2.13/2.13	2.43/2.43	1.22/1.22	1.58/1.58	2.08/2.08 2.47/2.47
Direction of rotation [viewed from stern]	Clockwise & counterclockwise			Clockwise & counterclockwise		
Lubrication system	Forced lubrication			Forced lubrication		
Lube oil specifications	API class: CF or higher, SAE grade: #30			API class: CF or higher, SAE grade: #30		
Max. lube oil capacity	1.8 L			5.4 L		
Dry weight - engine & gear	388 kg [855 lbs]			411 kg [906 lbs]		

* Other marine gearboxes and configurations available upon request. Contact your local supplier for more information

ACCESSORIES

Standard engine package

- Exhaust mixing elbow [L-type]
- Alternator 12V - 130A
- B25 panel
- Flexible mounts
- Mechanical throttle sensor
- Fresh water expansion tank

Optional accessories

- High-riser mixing elbow [instead of L-elbow]
- Secondary alternator 12V - 130A or 24V - 110A including smart regulator
- C35 panel
- Extension harness [3m, 5m, 10m, 20m]
- Second station
- Sidemount control head
- VC20 Vessel Control System

- JC20A Inboard Joystic
- NMEA2000 Engine monitoring system
- Semi 2-pole
- SOLAS including certificate [factory fit only]
- Hot water connection
- Water separator
- Man Over Board Switch [single]
- C-Type trolling [KMH50 only]
- On-board spare parts kit

NOTE: All data subject to change without notice. Text and illustrations are not binding.