

MARINER 1450T A 14.1 kVA 50 Hz

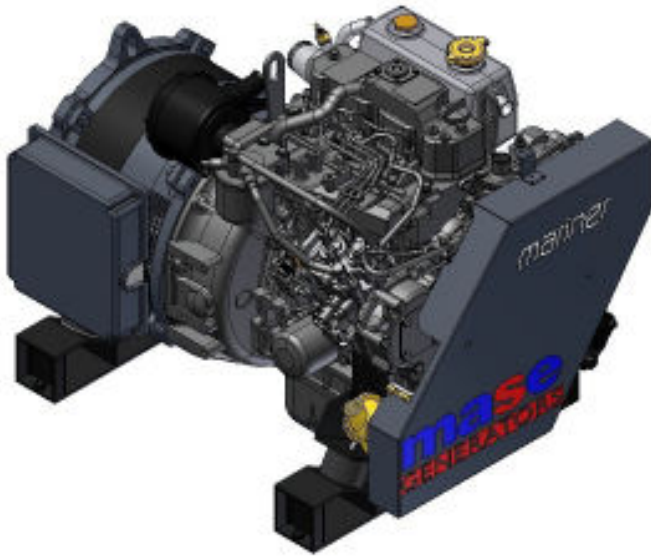

Remote Control Panel

Remote control panel was designed to include, in only one single panel, all switches, control devices and protection devices. Components are the following :

- Engine cut-off module for automatic stop in case of high water temperature, low oil pressure and high alternator temperature.
- Hour-meter.
- Start-stop button.
- Breaker for protection against overload and short circuit.
- Thermal switch for D.C. electric circuit.

Engine

- Easy access for maintenance to feeding system, lubrication, sea/water pump and air filter.
- Easy access to Oil and fuel filters.
- Safety stop in case of low oil pressure.
- Safety stop in case of high water/exhaust gas temperature.

Alternator

- Synchronous, 4 poles, self-excited with AVR.
- Rotor and stator coated with epoxy resin against external agents.
- Rotor dynamically balanced.
- Insulation class H.

Engine	50 Hz
Model	Yanmar 3TNV88
Type	Diesel 4 stroke
Cylinders (nr.)	3
Cylinder block material	Cast iron
Bore (mm. - in.)	88 - 3.46
Stroke (mm. - in.)	90 - 3.54
Displacement (cc. - CID)	1642 - 100
Power (hp)	18.4
RPM	1500
Combustion system	Direct
Engine head material	Cast iron
Speed governor	Centrifugal mechanical
Lubrication system	Forced
Oil sump capacity with filter (lt. - US qt)	6.7 - 7.1
Engine stop system	Stop solenoid
Fuel pump	Electric
Fuel pump discharge (cm. - ft)	70 - 2.3
Max fuel consumption (l/h-gal/h)	4 - 1.05
Starting battery (Ah-V)	80 - 12
Battery charger (Ah-V)	40 - 12
Starter (kW-V)	1,2 - 12
Max. inclination	30°
Water pump flow (l/min. - gal/min.)	25 - 6.6

Alternator	50 Hz
Type	Synchronous, 4-poles, self-excited
Cooling	Air
Voltage (V)	400
Frequency (Hz)	50
Max. power (kVA)	14.1
Continuous power (kVA)	12.7
Power factor (cos Φ)	0.8
Insulating class	H
Voltage stability	$\pm 2\%$
Frequency stability	$\pm 5\%$

Cooling system

The cooling of the engine is based on a closed inner flow of coolant. The system is based on a cupronickel heat exchanger seawater/coolant type, where the thermal exchange occurs between coolant and seawater. Two separate pumps contribute to the flow of the coolant and the sea water.

1450T A 50 Hz



50 Hz

Dimensions (Leng. x Width x Height)	875 x 570 x 664 mm (34.4 - 22.4 - 26.14 in)
Weight	294 kg (647 lb)

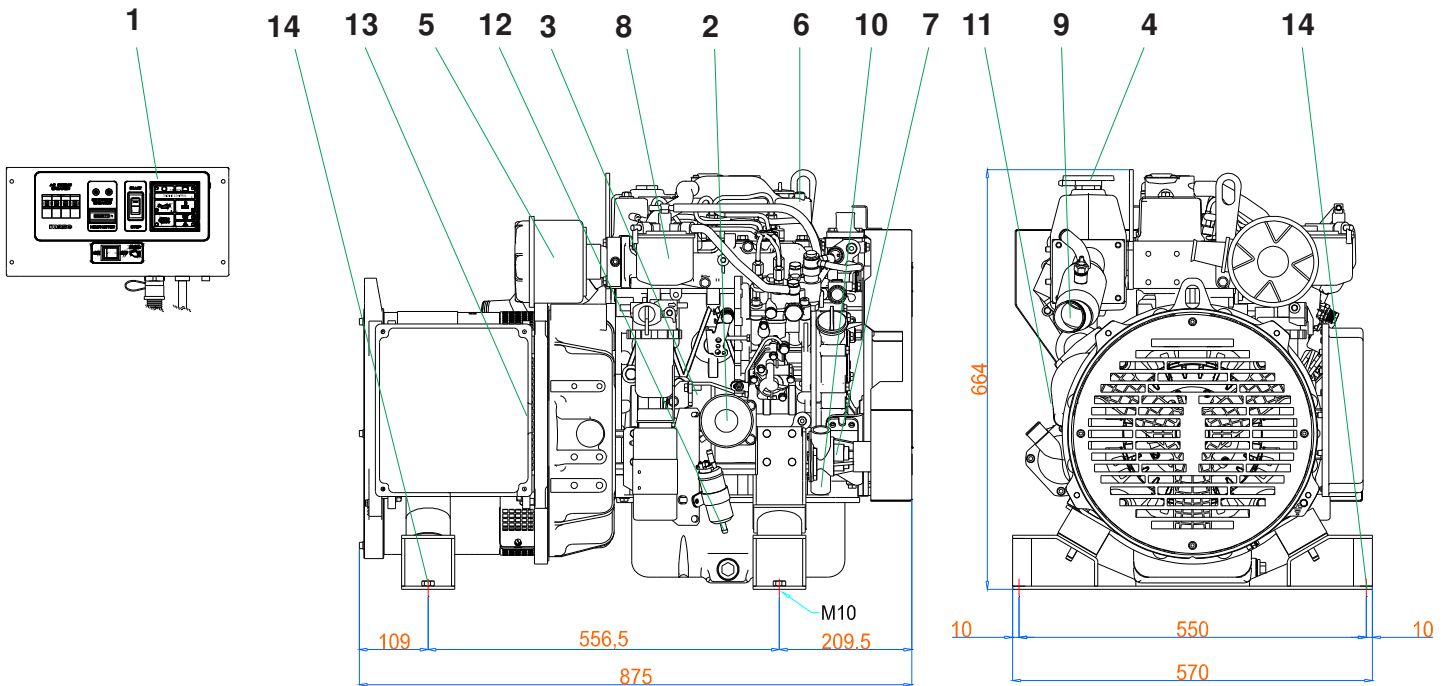

- | | |
|---------------------------------|--|
| 1 - Control panel | 8 - Fuel filter |
| 2 - Engine oil filter cartridge | 9 - Seawater exhaust connection (ø 50mm) |
| 3 - Oil dipstick | 10 - Seawater inlet (ø 16mm) |
| 4 - Engine oil cap | 11 - Battery connection |
| 5 - Air filter | 12 - Fuel tank connection (ø 8mm) |
| 6 - Closed circuit water pump | 13 - Electric cables outlet |
| 7 - Seawater pump | 14 - Fixing stirrups |

FITTINGS

- EXHAUST COMPONENTS KIT
- SIPHON BREAK
- WATER-GAS SEPARATOR KIT
- STARTING REMOTE CONTROL PANEL WITH INSTRUMENTS

*This drawing is only a reference and is not indicatly for the installation. For more information, you may contact your local dealer or **mase generators S.p.A.***

***mase generators S.p.A.** reserves the right to change the design or specifications without notice and without any obligations or liability whatsoever. For more information, you may contact your local **mase** dealer.*

Dealer:



MASE GENERATORS S.p.A. Via Tortona, 345
47522 Cesena (FC) Italy
Tel. +39-0547-354311 Fax. +39-0547-317555
Email : mase@masegenerators.com