

MARINER

900 A

9 kW

50 Hz

MARINER

1020 A

10 kW

60 Hz

Remote Control Panel

Remote control panel was designed to include, in only one single panel, all switches, control devices and protection devices. Components are the following :

- Engine cut-off module for automatic stop in case of high water temperature, low oil pressure and high alternator temperature.
- Hour-meter.
- Start-stop button.
- Breaker for protection against overload and short circuit.
- Thermal switch for D.C. electric circuit.

Engine

- Easy access for maintenance to feeding system, lubrication, sea/water pump and air filter.
- Easy access to Oil and fuel filters.
- Safety stop in case of low oil pressure.
- Safety stop in case of high water/exhaust gas temperature.

Alternator

- Synchronous, 4 poles, self-excited with AVR.
- Rotor and stator coated with epoxy resin against external agents.
- Rotor dynamically balanced.
- Insulation class H.

Engine	50 Hz	60Hz
Model	Yanmar 3TNV82	
Type	Diesel 4 stroke	
Cylinders (nr.)	3	
Cylinder block material	Cast iron	
Bore (mm. - in.)	82 - 3.2	
Stroke (mm. - in.)	84 - 3.3	
Displacement (cc. - CID)	1330 - 81	
Power (hp)	15.04	18.07
RPM	1500	1800
Combustion system	Indirect	
Engine head material	Cast iron	
Speed governor	Centrifugal mechanical	
Lubrication system	Forced	
Oil sump capacity with filter (lt. - US qt)	5.5 - 5.2	
Engine stop system	Stop solenoid	
Fuel pump	Electric	
Fuel pump discharge (cm. - ft)	70 - 2.3	
Max fuel consumption (l/h-gal/h)	3.2 - 0.85	3.6 - 0.95
Starting battery (Ah-V)	70 - 12	
Battery charger (Ah-V)	40 - 12	
Starter (kW-V)	1,4 - 12	
Max. inclination	30°	
Water pump flow (l/min. - gal/min.)	25 - 6.6	28 - 7.4

Alternator	50 Hz	60Hz
Type	Synchronous, 4-poles, self-excited	
Cooling	Air	
Voltage (V)	115 - 230	120 - 240
Frequency (Hz)	50	60
Nominal current (A)	78.2 - 39.1	83.3 - 41.6
Max. power (kW)	9	10
Continuous power (kW)	8.2	9.5
Power factor (cos Φ)	1	
Insulating class	H	
Voltage stability	±2%	
Frequency stability	±5%	

Cooling system

The cooling of the engine is based on a closed inner flow of coolant. The system is based on a cupronickel heat exchanger seawater/coolant type, where the thermal exchange occurs between coolant and seawater. Two separate pumps contribute to the flow of the coolant and the sea water.

	50 Hz	60Hz
Dimensions (Lenght x Width x Height)	764 x 520 x 626 mm (30 - 20.5 - 24.6 in)	
Weight	255 kg (561 lb)	

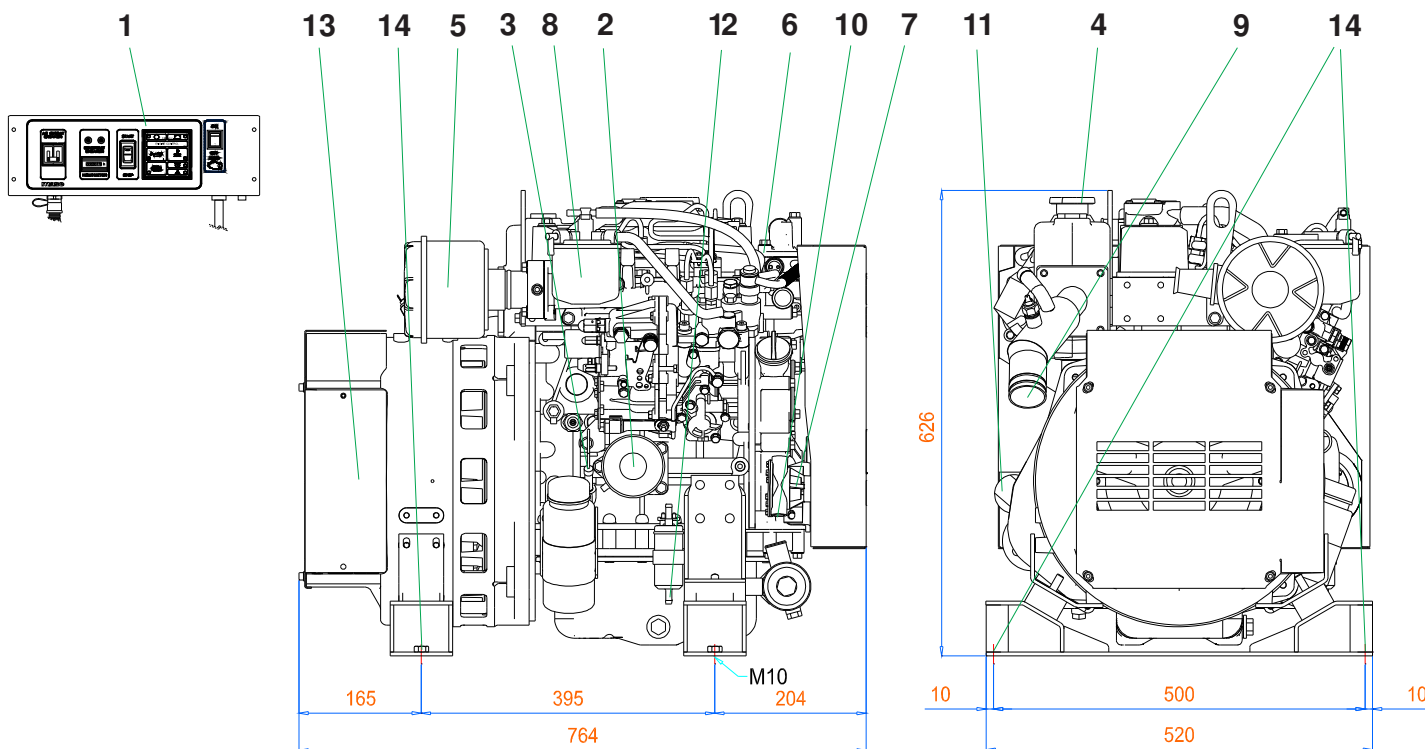

- | | |
|---------------------------------|--|
| 1 - Control panel | 8 - Fuel filter |
| 2 - Engine oil filter cartridge | 9 - Seawater exhaust connection (ø 50mm) |
| 3 - Oil dipstick | 10 - Seawater inlet (ø 16mm) |
| 4 - Engine oil cap | 11 - Battery connection |
| 5 - Air filter | 12 - Fuel tank connection (ø 8mm) |
| 6 - Closed circuit water pump | 13 - Electric cables outlet |
| 7 - Seawater pump | 14 - Fixing stirrups |

FITTINGS

EXHAUST COMPONENTS KIT
SIPHON BREAK
WATER-GAS SEPARATOR KIT
STARTING REMOTE CONTROL PANEL WITH INSTRUMENTS

*This drawing is only a reference and is not indicatly for the installation. For more information, you may contact your local dealer or **mase** generators S.p.A..*

mase generators S.p.A. reserves the right to change the design or specifications without notice and without any obligations or liability whatsoever. For more information, you may contact your local **mase** dealer.

Dealer: